

Connect Spooling spool gun to old MAG 251

(1) Drill hole at front panel add a socket a switch(need purchase)

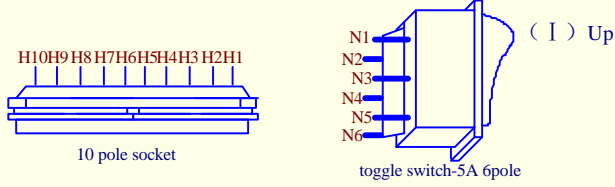

(2) modify MAG-Control circuit board wire connect

1. Modify CN1 connector wire, as following:

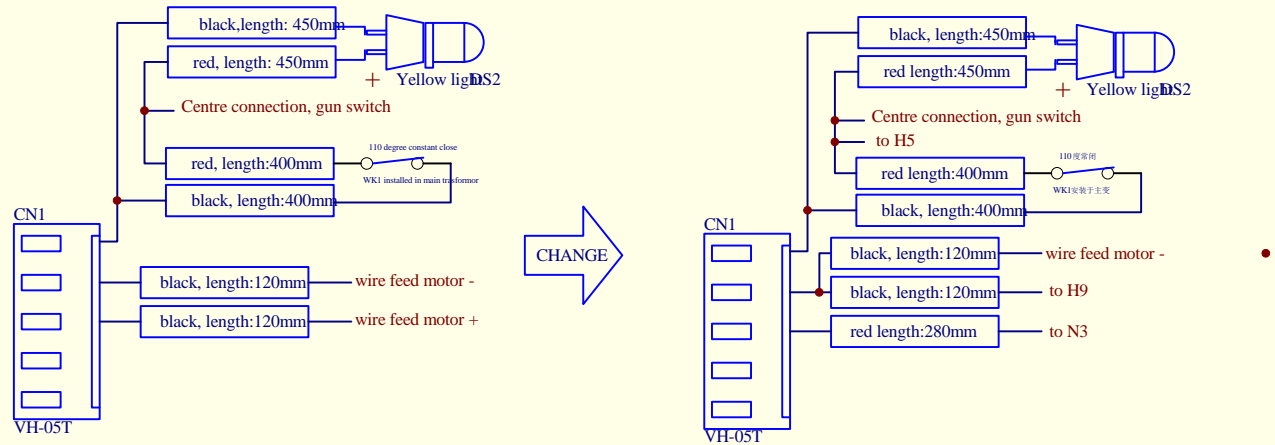

1. Modify CN2 connector wire, as following:

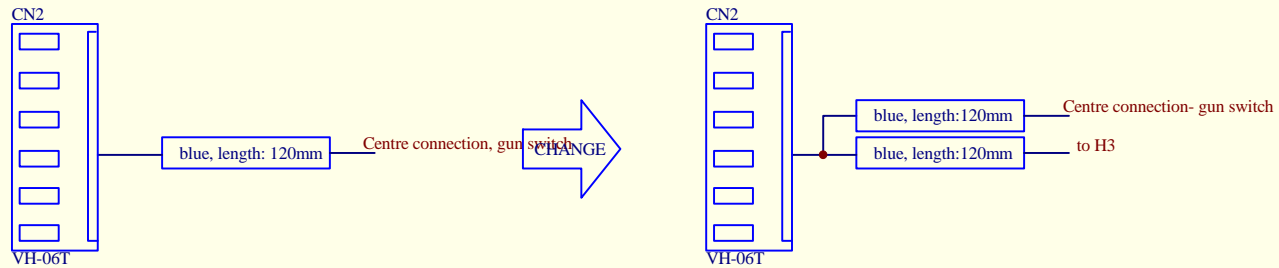

1. Modify CN3 connector wire, as following:

